

mm inch

FEATURES

- **High sensitivity: 150 mW/200 mW**
- **A wide range of ambient temperature: -40°C to +70°C -40°F to +158°F**
- **Sealed construction**
- **Rating: 1 A 30 V DC**

SPECIFICATIONS

Contact

Arrangement	1 Form C	
Initial contact resistance, max. (By voltage drop 6 V DC 1 A)	100 mΩ	
Contact material	Gold-clad silver	
Rating (resistive)	Nominal switching capacity	1 A 30 V DC
	Max. switching power	30 W
	Max. switching voltage	60 V DC
	Max. switching current	1 A
	Max. carrying current	2 A
Expected life (min. operations)	Mechanical (at 180 cpm)	10 ⁷
	Electrical (at 20 cpm) 1 A 30 V DC	10 ⁵

Coil

Nominal operating power	Standard type	200 mW
	High sensitivity type	150 mW

Remarks

- * Specifications will vary with foreign standards certification ratings.
- *1 Measurement at same location as "Initial breakdown voltage" section
- *2 Detection current: 10mA
- *3 Excluding contact bounce time
- *4 Half-wave pulse of sine wave: 11ms; detection time: 10μs
- *5 Half-wave pulse of sine wave: 6ms
- *6 Detection time: 10μs
- *7 Refer to 6. Conditions for operation, transport and storage mentioned in AMBIENT ENVIRONMENT

Characteristics (at 25°C 77°F, 50% Relative humidity)

Max. operating speed	20 cpm (at nominal voltage)	
Initial insulation resistance*1	Between contacts	Min. 100 MΩ at 500 V DC
	Between contact and coil	Min. 100 MΩ at 500 V DC
Initial breakdown voltage*2	Between open contacts	500 Vrms
	Between contacts and coil	1,000 Vrms
Operate time*3 (at nominal voltage)	Max. 5 ms (approx. 2 ms)	
Release time (without diode)*3 (at nominal voltage)	Max. 4 ms (approx. 1 ms)	
Temperature rise at nominal voltage Contact carrying current 1 A at 20°C	Max. 50°C	
Shock resistance	Functional*4	Min. 98 m/s ² (10 G)
	Destructive*5	Min. 980 m/s ² (100 G)
Vibration resistance	Functional*6	58.8 m/s ² {6 G}, 10 to 55 Hz at double amplitude of 1 mm
	Destructive	117.6 m/s ² {12 G}, 10 to 55 Hz at double amplitude of 2 mm
Conditions for operation, transport and storage*7 (Not freezing and condensing at low temperature)	Ambient temp.	-40°C to +70°C -40°F to +158°F
	Humidity	5 to 85% R.H.
Unit weight	1.8 g .063 oz	

TYPICAL APPLICATIONS

- Automotive: Switching to small motor
1) Automirror controller
2) Retractable head light controller
- Push button device: Dial pulsing
- Low-voltage signal switching and motor control of small home appliances such as portable video tape recorders and audio devices.
- Operating of dish-control motors for PCs and word processors

ORDERING INFORMATION



Contact arrangement	Sensitivity	Coil voltage (DC)
1: 1 Form C	Nil: High sensitivity 150 mW Z: Standard 200 mW	1.5, 3, 4.5, 5, 6, 9, 12, 24 V

Standard packing: Tube: 50 pcs.; Case: 2,000 pcs.

TYPES AND COIL DATA (at 20°C 68°F)

200 mW Standard type

Part No.	Nominal voltage, V DC	Pick-up voltage, V DC (max.)	Drop-out voltage, V DC (min.)	Coil resistance, Ω (±10%)	Nominal operating current, mA	Nominal operating power, mW	Max. allowable voltage, V DC (at 70°C 158°F)
HY1Z-1.5V	1.5	1.125	0.15	11.25	133.3	200	1.8
HY1Z-3V	3	2.25	0.3	45	66.7	200	3.6
HY1Z-4.5V	4.5	3.375	0.45	101.2	44.5	200	5.4
HY1Z-5V	5	3.75	0.5	125	40	200	6
HY1Z-6V	6	4.5	0.6	180	33.3	200	7.2
HY1Z-9V	9	6.75	0.9	405	22.2	200	10.8
HY1Z-12V	12	9	1.2	720	16.7	200	14.4
HY1Z-24V	24	18	2.4	2,880	8.3	200	28.8

150 mW High sensitivity type

Part No.	Nominal voltage, V DC	Pick-up voltage, V DC (max.)	Drop-out voltage, V DC (min.)	Coil resistance, Ω (±10%)	Nominal operating current, mA	Nominal operating power, mW	Max. allowable voltage, V DC (at 70°C 158°F)
HY1-1.5V	1.5	1.125	0.15	15	100	150	2.1
HY1-3V	3	2.25	0.3	60	50	150	4.2
HY1-4.5V	4.5	3.375	0.45	135	33.3	150	6.3
HY1-5V	5	3.75	0.5	166	30.1	150	7
HY1-6V	6	4.5	0.6	240	25	150	8.4
HY1-9V	9	6.75	0.9	540	16.7	150	12.6
HY1-12V	12	9	1.2	960	12.5	150	16.8
HY1-24V	24	18	2.4	3,840	6.25	150	33.6

DIMENSIONS

mm inch

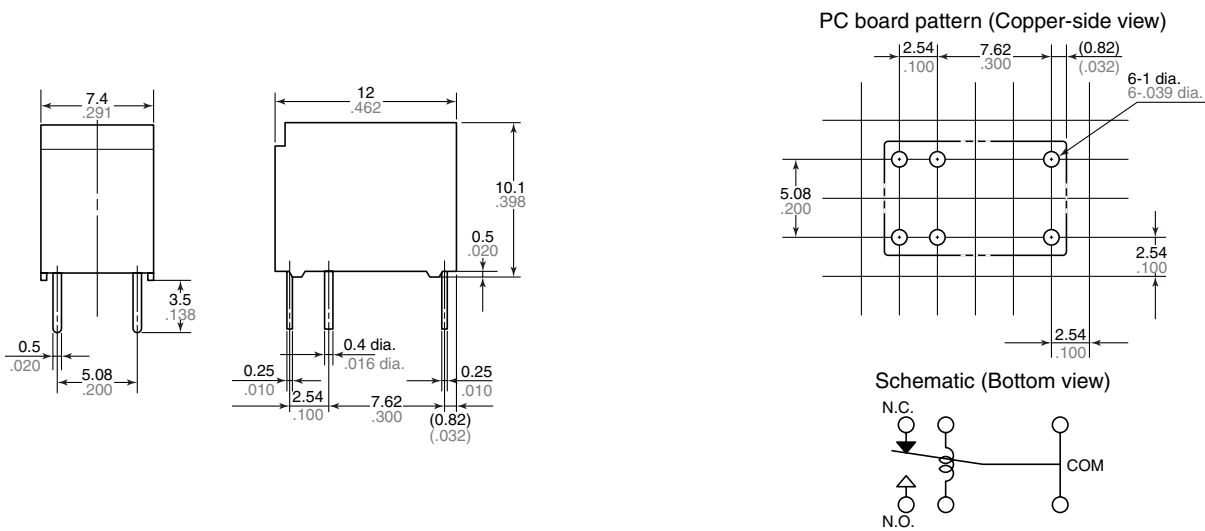

General tolerance: ±0.3 ±0.12

Tolerance: ±0.1 ±0.04

REFERENCE DATA

1. Maximum switching power

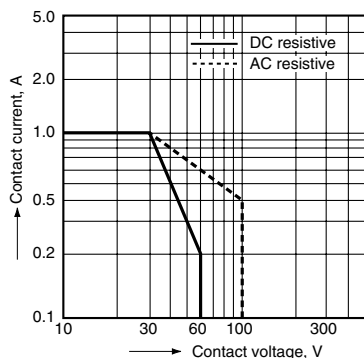

2. Life curve

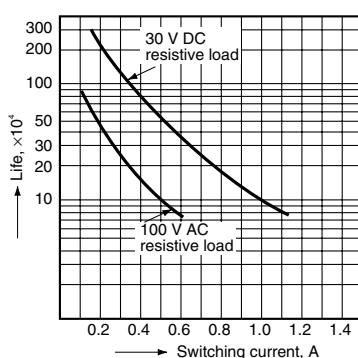

3. Mechanical life

Tested sample: HY1Z-12V, 10 pcs.
Ambient temperature: 20°C to 25°C 68°F to 77°F

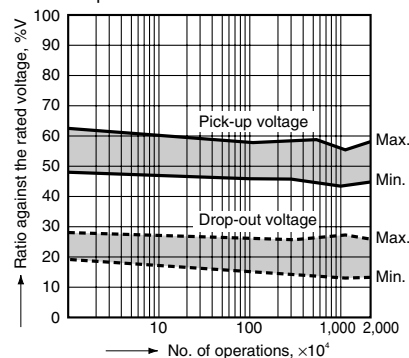

4. Electrical life

Tested sample: HY1-12V, 6 pcs.
Condition: 1 A 30 V DC resistive load, 30 cpm

Circuit:

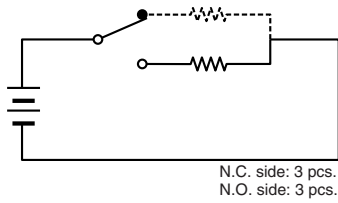

Change of pick-up and drop-out voltage

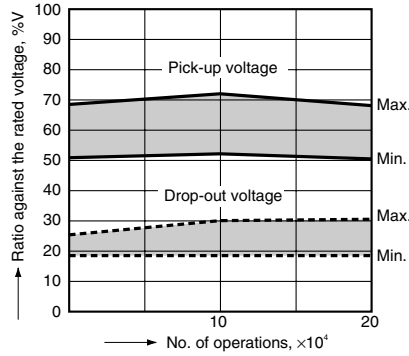

Change of contact resistance

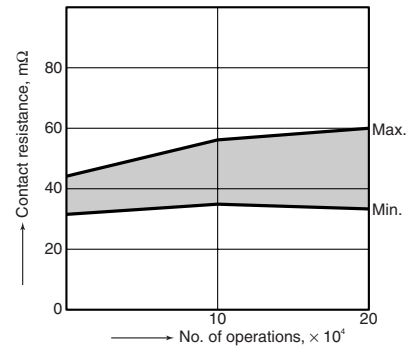

5-(1). Coil temperature rise (150 mW high sensitivity type)

Tested sample: HY1-9V, 5 pcs.
Ambient temperature: 24°C 75°F

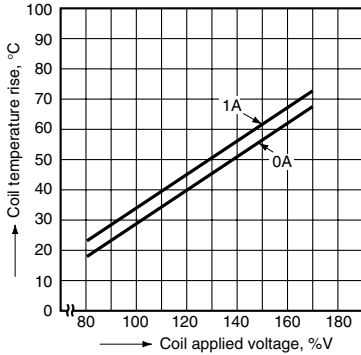

5-(2). Coil temperature rise (200 mW Standard type)

Tested sample: HY1Z-12V, 5 pcs.
Ambient temperature: 23°C 74°F

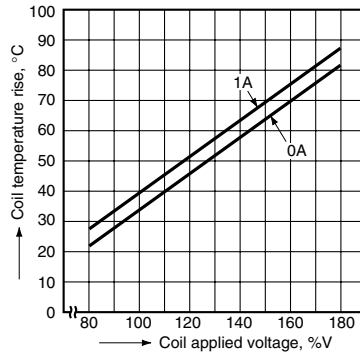

6. Operate/release time characteristics

Tested sample: HY1Z-12V, 5 pcs.
Ambient temperature: 25°C 77°F

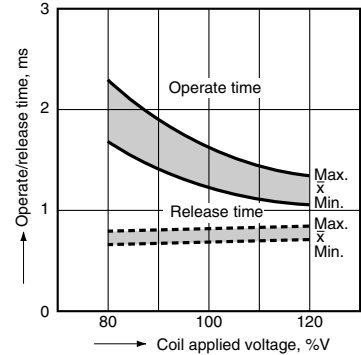

7. Distribution of pick-up and drop-out voltages

Tested sample: HY1-12V, 50 pcs.
Ambient temperature: 23°C 74°F

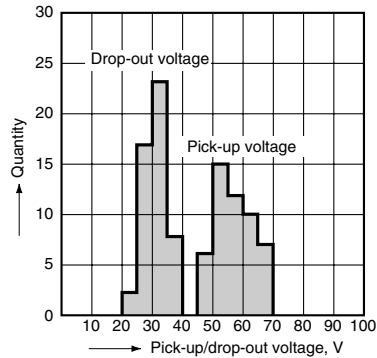

8. Distribution of contact resistance

Tested sample: HY1-12V, 50 pcs.
N.C. side N.O. side

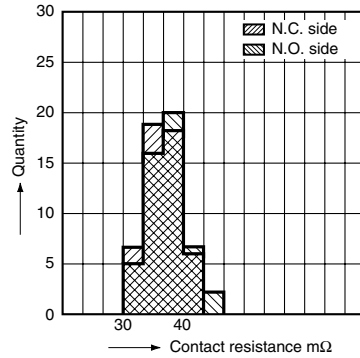

9. Malfunction shock

Tested sample: HY1Z-12V, 6 pcs.

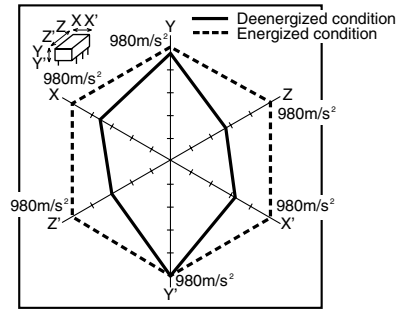

NOTE

Soldering and cleaning

HY relays have the sealed construction. It is possible to do automatic soldering and automatic cleaning, but avoid the ultrasonic cleaning.

For cleaning, it is recommended that a fluorinated hydrocarbon or other alcoholic solvent be used.

For Cautions for Use, see Relay Technical Information